

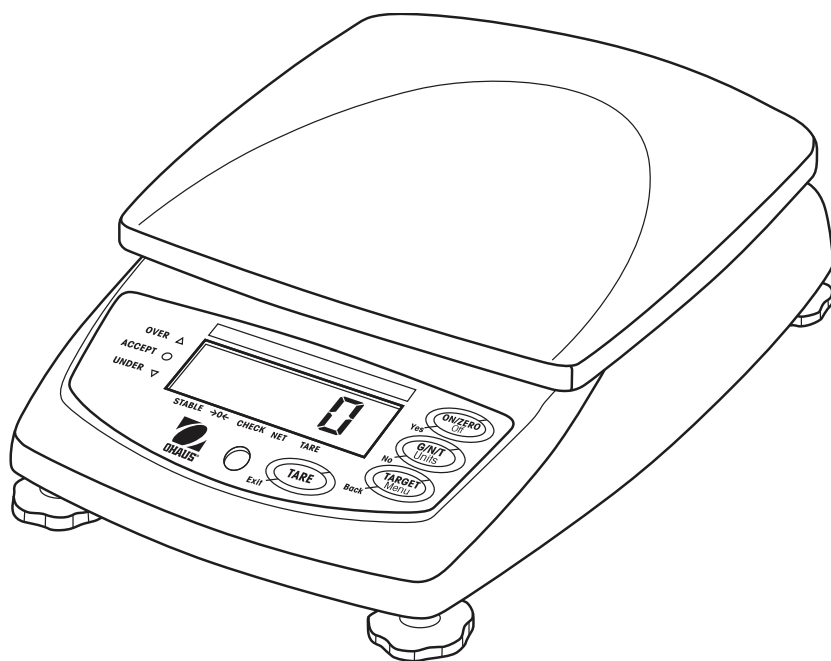



**FD Series  
Instruction Manual**

**Serie FD  
Manual de instrucciones**

**Série FD  
Guide de l'utilisateur**



	<p>This product conforms to the EMC Directive 2004/108/EC and the Low Voltage Directive 2006/95/EC. The complete Declaration of Conformity is available from Ohaus Corporation</p>
	<p>Este producto se conforma con el EMC 2004/108/EC directivo y la baja tensión 2006/95/EC directivo. El declaración completo de la conformidad está disponible de Ohaus Corporation.</p>
	<p>Ce produit se conforme à l'EMC 2004/108/EC directif et la basse tension 2006/95/EC directif. La déclaration complète de la conformité est fournie par Ohaus Corporation.</p>

### Important notice for verified weighing instruments



Weighing Instruments verified at the place of manufacture bear one of the preceding mark on the packing label and the green 'M' (metrology) sticker on the descriptive plate. They may be put into service immediately.



Weighing Instruments to be verified in two stages have no green 'M' (metrology) on the descriptive plate and bear one of the preceding identification mark on the packing label. The second stage of the initial verification must be carried out by the approved service organization of the authorized representative within the EC or by the national weight & measures (W+M) authorities.

The first stage of the initial verification has been carried out at the manufacturers work. It comprises all tests according to the adopted European standard EN 45501:1992, paragraph 8.2.2.

If national regulations limit the validity period of the verification, the user of the weighing instrument must strictly observe the re-verification period and inform the respective W+M authorities.

### Notificación importante para instrumentos de pesaje verificados



Los instrumentos de pesaje verificados en el sitio de fabricación llevan una de las marcas precedentes en el rótulo del empaque y la etiqueta de la 'M' verde (metrología) en la placa descriptiva. Estos instrumentos se pueden poner en funcionamiento inmediatamente.



Los instrumentos de pesaje a ser verificados en dos etapas no tienen ninguna 'M' verde (metrología) en la placa descriptiva, y presentan una de las marcas de identificación precedentes sobre el rótulo del empaque. La segunda etapa de la verificación inicial debe ser llevada a cabo por la organización de servicio aprobada del representante autorizado dentro de la CE o por las autoridades nacionales de pesos y medidas.

La primera etapa de la verificación inicial ha sido llevada a cabo en el sitio de fabricación. Ésta comprende todas las pruebas estipuladas por el estándar europeo adoptado: EN 45501:1992, párrafo 8.2.2.

Si las normas nacionales limitan el periodo de validez de la verificación, el usuario del instrumento de pesaje debe seguir estrictamente el periodo de re-verificación e informar a las correspondientes autoridades de pesos y medidas.

### Avis important pour les instruments de pesage vérifiés



Les instruments de pesage vérifiés sur le site de fabrication portent l'une des marques précédentes sur l'étiquette de l'emballage avec un autocollant M (pour Métrologie) en vert sur la plaque descriptive. Ces instruments peuvent être immédiatement mis en service.



Les instruments de pesage à vérifier en deux étapes ne portent pas d'autocollant M (pour Métrologie) en vert sur la plaque descriptive et portent l'une des marques d'identification précédentes sur l'étiquette de l'emballage. La deuxième étape de la vérification initiale doit être exécutée par l'organisation de service homologuée du représentant agréé au sein de la CE ou par les autorités nationales de poids et mesures.

La première étape de la vérification initiale a été exécutée sur le site du fabricant. Elle se compose des tests requis par la norme européenne EN45501:1992, paragraphe 8.2.2.

Si des règlements nationaux limitent la durée de validité de la vérification, il incombe à l'utilisateur dudit instrument de pesage de respecter strictement la période de re-vérification et d'informer les autorités de poids et mesures respectives.

### Disposal



In conformance with the European Directive 2002/96 EC on Waste Electrical and Electronic Equipment (WEEE) this device may not be disposed of in domestic waste. This also applies to countries outside the EU, per their specific requirements.

Please dispose of this product in accordance with local regulations at the collecting point specified for electrical and electronic equipment.

If you have any questions, please contact the responsible authority or the distributor from which you purchased this device.

Should this device be passed on to other parties (for private or professional use), the content of this regulation must also be related.

Thank you for your contribution to environmental protection.

### Eliminación de residuos



De conformidad con las exigencias de la directiva europea 2002/96 CE sobre residuos de aparatos eléctricos y electrónicos (RAEE), este equipo no puede eliminarse como basura doméstica. Esta prohibición es asimismo válida para los países que no pertenecen a la UE cuyas normativas nacionales en vigor así lo reflejan.

Elimine este producto, según las disposiciones locales, mediante el sistema de recogida selectiva de aparatos eléctricos y electrónicos.

Si tiene alguna pregunta al respecto, diríjase a las autoridades responsables o al distribuidor que le proporcionó el equipo.

Si transfiere este equipo (por ejemplo, para la continuación de su uso con fines privados, comerciales o industriales), deberá transferir con él esta disposición.

Muchas gracias por su contribución a la conservación medioambiental.

### Elimination



En conformité avec les exigences de la directive européenne 2002/96 CE relative aux déchets d'équipements électriques et électroniques (DEEE), cet appareil ne doit pas être éliminé avec les déchets ménagers. Logiquement, ceci est aussi valable pour les pays en dehors de l'UE conformément aux réglementations nationales en vigueur.





Veillez éliminer cet appareil conformément aux prescriptions locales dans un conteneur séparé pour appareils électriques et électroniques.

Pour toute question, adressez-vous aux autorités compétentes ou au revendeur chez qui vous avez acheté cet appareil.

En cas de remise de cet appareil (p. ex. pour une utilisation privée ou artisanale/industrielle), cette prescription doit être transmise en substance.

Merci pour votre contribution à la protection de l'environnement.

Compliance to the following standards is indicated by the corresponding marking on the product.  
 El cumplimiento con los siguientes estándares se indica mediante el correspondiente marcado sobre el producto.  
 La conformité aux normes suivantes est indiquée par le marquage correspondant sur le produit.

<b>Marking</b> <b>Marcado</b> <b>Marquage</b>	<b>Standard</b> <b>Estándar</b> <b>Normes</b>
	UL60950-1 : 2003
	AS/NZS4251.1, AS/NZS4252.1
	NSF/ANSI 169
	NSF/ANSI /3-A 14159-1

**FCC Note**

This equipment has been tested and found to comply with the limits for a Class B digital device, pursuant to Part 15 of the FCC Rules. These limits are designed to provide reasonable protection against harmful interference in a residential installation. This equipment generates, uses and can radiate radio frequency energy and, if not installed and used in accordance with the instructions, may cause harmful interference to radio communications. However, there is no guarantee that interference will not occur in a particular installation. If this equipment does cause harmful interference to radio or television reception, which can be determined by turning the equipment off and on, the user is encouraged to try to correct the interference by one or more of the following measures:

- Reorient or relocate the receiving antenna.
- Increase the separation between the equipment and receiver.
- Connect the equipment into an outlet on a circuit different from that to which the receiver is connected.
- Consult the dealer or an experienced radio/TV technician for help.

**Industry Canada Note**

This Class B digital apparatus complies with the Canadian ICES-003.  
 Cet appareil numérique de la classe B est conforme à la norme NMB-003 du Canada.

**ISO 9001 Registration**

In 1994, Ohaus Corporation, USA, was awarded a certificate of registration to ISO 9001 by Bureau Veritus Quality International (BVQI), confirming that the Ohaus quality management system is compliant with the ISO 9001 standard's requirements. On May 15, 2003, Ohaus Corporation, USA, was re-registered to the ISO 9001:2000 standard.

**Registro ISO 9001**

En 1994, Bureau Veritus Quality International (BVQI) le otorgó a Ohaus Corporation, EE.UU., un certificado de registro ISO 9001 el cual confirma que el sistema administrativo de calidad de Ohaus cumple con los requerimientos del estándar ISO 9001. En mayo 15 del 2003, Ohaus Corporation, EE.UU., fue registrada nuevamente al estándar ISO 9001:2000.

**Enregistrement ISO 9001**

En 1994, le Bureau Veritus Quality International (BVQI) a octroyé la certification d'enregistrement ISO 9001 à Ohaus Corporation, États-Unis d'Amérique, confirmant que le système de gestion de la qualité Ohaus était conforme aux conditions normalisées de l'ISO 9001. Le 15 mai 2003, Ohaus Corporation, États-Unis d'Amérique, a été ré-enregistrée à la norme ISO 9001:2000.

## TABLE OF CONTENTS

1 INTRODUCTION .....	EN-3
1.1 Product Description .....	EN-3
1.2 General Features .....	EN-3
1.3 Safety Precautions .....	EN-4
2 INSTALLATION EN-5	
2.1 Unpacking EN-5	
2.2 Installing Components .....	EN-5
2.3 Selecting the Location .....	EN-5
2.4 Connecting Power .....	EN-5
2.4.1 AC Power .....	EN-5
2.4.2 Battery Power .....	EN-6
2.5 Initial Calibration .....	EN-6
3 OPERATION .....	EN-7
3.1 Overview of Parts and Controls .....	EN-7
3.2 Control Functions .....	EN-9
3.3 Basic Operation .....	EN-9
3.3.1 Turning On .....	EN-9
3.3.2 Turning Off .....	EN-9
3.3.3 Zeroing .....	EN-9
3.3.4 Taring .....	EN-9
3.3.5 Displaying Gross and Tare Values .....	EN-10
3.3.6 Changing Unit of Measure .....	EN-10
3.4 Menu EN-10	
3.4.1 Menu Structure .....	EN-10
3.4.2 Menu Navigation .....	EN-11
3.4.3 Changing Menu Settings .....	EN-11
3.5 Application Modes .....	EN-11
3.5.1 Weighing .....	EN-11
3.5.2 Checkweighing .....	EN-11
3.6 Checkweigh Target Settings .....	EN-12
3.7 Scale Settings .....	EN-13
3.7.1 Calibration sub-menu .....	EN-13

3.7.2 Setup sub-menu .....	EN-15
3.7.3 Readout sub-menu .....	EN-16
3.7.4 Unit sub-menu .....	EN-17
3.7.5 Mode sub-menu .....	EN-18
3.7.6 Lockout sub-menu .....	EN-19
3.8 Legal for trade Settings .....	EN-20
3.9 Sealing the Scale .....	EN-20
4 MAINTENANCE EN-21	
4.1 Calibration EN-21	
4.2 Cleaning EN-21	
4.3 Troubleshooting .....	EN-21
4.4 Service Information .....	EN-22
4.5 Accessories EN-22 .....	
5 TECHNICAL DATA EN-23	
5.1 Drawings EN-23	
5.2 Specifications .....	EN-23
Tables	
Table 3-1 Parts and Controls .....	EN-8
Table 3-2 Menu Structure .....	EN-10
Table 3-3 Calibration Points .....	EN-13
Table 4-1 Troubleshooting .....	EN-21
Table 4-2 Error Codes .....	EN-22
Table 5-1 Specifications .....	EN-24
Table 5-2 Specifications .....	EN-25
Figures	
Figure 2-1 Installing .....	EN-7
Figure 2-2 Leveling Indicator .....	EN-7
Figure 2-3 Bottom of Scale .....	EN-7
Figure 3-1 Parts EN-7	
Figure 3-2 Control Panel .....	EN-7
Figure 3-3 Display .....	EN-8
Figure 3-4 Security Switch Settings .....	EN-20
Figure 3-5 Sealing Methods .....	EN-20
Figure 5-1 Scale Dimensions .....	EN-23

# 1 INTRODUCTION

This manual contains installation, operation and maintenance instructions for the FD Series scale. Please read the manual completely before installation and operation.

## 1.1 Product Description

The FD Series is an easy-to-clean and rugged compact scale engineered specifically for hygiene-oriented environments and to enhance productivity. With its stainless steel construction, compact size and food safety approvals, it is ideal for use in sanitary and food preparation areas such as kitchens, bakeries, restaurants, packaging and processing facilities. Battery operation and a backlit LCD display make for a portable scale that can be easily carried to various locations and used under a wide range of lighting conditions. Its fast display update speed, straight forward 4-button operation and configurable checkweighing mode make the FD Series a simple yet flexible scale for general weighing, portioning and sorting applications. This precision weighing scale will provide years of service when properly cared for.

## 1.2 General Features

- Capacity Models(FDxx,): 3kg x .5g / 6lb x .001lb, 6kg x 1g / 15lb x .002lb, 15kg x 2g / 30 lb x .005lb
- Maximum Displayed Resolution(FDxx) 1:6000 to 7500
- Type-approved Resolution(FDxx) 1:3000
- Capacity Models(FDxxH): 3kg x .1g / 6lb x .0002lb, 6kg x 0.2g / 15lb x .001lb, 15kg x 1g / 30 lb x .001lb
- Maximum Displayed Resolution(FDxxH) 1:30000
- Food Safety Certifications: NSF, USDA/AMS
- Stainless steel low-profile enclosure
- Stainless steel weighing pan: 209 x 209 mm (8.2" x 8.2")
- Backlit LCD display: 5-digit 7-segment, 19mm (.75") digit height
- Multiple weighing units: kg, g, lb, oz (decimal or fractional), lb:oz (decimal or fractional oz)
- Display update speed: within 2 seconds
- 3-color LED with configurable audible alert checkweigh indications
- 4-button control panel, including dedicated Tare button
- Built-in level indicator and adjustable slip-resistant rubber leveling feet
- Built-in rechargeable lead-acid battery: 120-hour operation on a 15-hour charge
- Battery status indicator with power-saving Auto-off function
- Gross, Net, Tare operation
- Auto-zero tracking operation
- Auto-tare operation
- Enhanced digital filtering
- Connection for accessory Foot Switch for remote tare operation



## 1.3 Safety Precautions



For safe and dependable operation of this scale, please comply with the following safety precautions:

- Verify that the input voltage printed on the AC Adapter's data label and the plug type matches the local AC power supply.
- Make sure that the power cord does not pose a potential obstacle or tripping hazard.
- Use only approved accessories and peripherals.
- Operate the scale only under ambient conditions specified in these instructions.
- Disconnect the scale from the power supply when cleaning the scale.
- Do not operate the scale in hazardous or unstable environments.
- Do not immerse the scale in water or other liquids.
- Avoid directly splashing the scale with water or other liquids.
- Do not drop heavy loads on the platform.
- Service should only be performed by authorized personnel.

## 2 INSTALLATION

### 2.1 Unpacking

Unpack and verify that the following components have been included:

- FD Scale
- Weighing Pan
- AC Adapter
- Instruction Manual
- Warranty Card
- Weights and Measures Sealing Kit

Save the packaging material. Repack the scale in the original packaging to ensure safe storage or transport of the product.

### 2.2 Installing Components

Place the weighing pan securely over the four load pads on the top of the scale. If using the optional foot switch, plug the foot switch connection into the appropriate receptacle on the underside of the scale (refer to Figure 2-3).

### 2.3 Selecting the Location

Operate the scale on a firm, level surface. Avoid locations with rapid temperature changes or excessive dust, air currents, vibrations, electromagnetic fields or heat.

Adjust the leveling feet so that the bubble is centered in the circle of the level indicator.

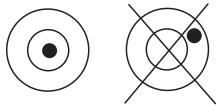

Figure 2-2. Leveling Indicator.

**NOTE:** The scale should be leveled each time its location is changed.

### 2.4 Connecting Power

#### 2.4.1 AC Power

Check to ensure that the voltage printed on the scale's data label matches your local line voltage. If this is not the case, DO NOT connect the scale to the power supply. Contact an OHAUS dealer for assistance.

Connect the AC adapter to the wall outlet. Connect the plug into the power receptacle on the underside of the scale.

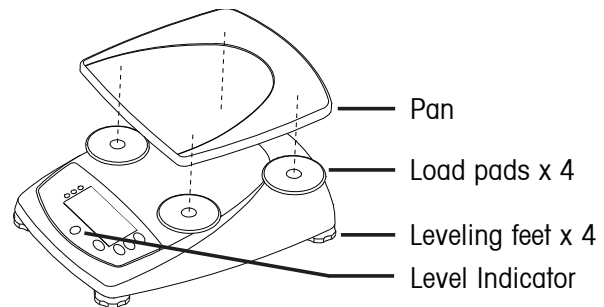

Figure 2-1. Installing Scale Components.

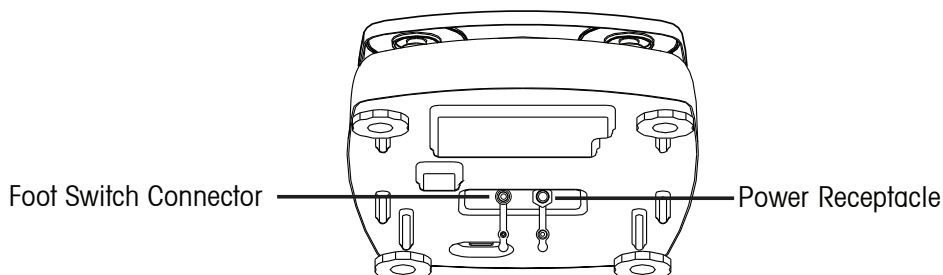

Figure 2-3. Bottom of Scale.



Before using the scale for the first time, the internal rechargeable battery should be fully charged for up to 15 hours. The scale can be operated during the charging process. The battery is protected against over charging and the scale can remain connected to the AC power line.

Plug the AC Adapter into the receptacle marked "Power In" located on the underside of the scale and allow it to charge. While the battery is charging, the segments in the battery symbol will alternately light. When the battery is fully charged, the battery symbol will disappear.

### 2.4.2 Battery Power

The scale can be operated on the internal rechargeable battery when AC power is not available. The scale will automatically switch to battery operation if there is a power failure or the power cord is removed. A fully charged battery can operate the scale for up to 120 hours (with the backlight off) independent of the AC power line.

During battery operation, the battery symbol will light to show the current discharge status of the battery (1 segment = 25% capacity). A flashing symbol indicates that the battery requires recharging. The scale will automatically turn off when the battery is fully discharged.



## CAUTION

**BATTERY IS TO BE REPLACED ONLY BY AN AUTHORIZED OHAUS SERVICE DEALER.**

**RISK OF EXPLOSION CAN OCCUR IF REPLACED WITH THE WRONG TYPE OR CONNECTED IMPROPERLY.**



Dispose of the lead acid battery according to local laws and regulations.

## 2.5 Initial Calibration

When the scale is first installed, a SPAN calibration should be performed to ensure accurate weighing results. Before performing the SPAN calibration, be sure to have the appropriate calibration weights. Refer to Section 3.7.1.

### 3 OPERATION

#### 3.1 Overview of Parts and Controls

Identify parts and controls using item numbers from Table 1.

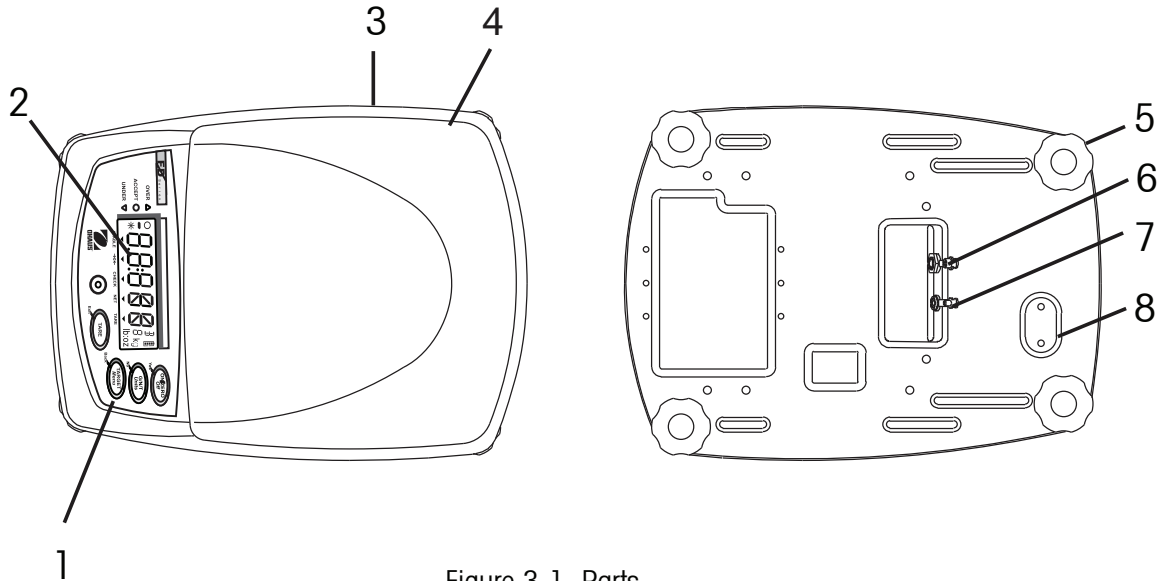

Figure 3-1. Parts.

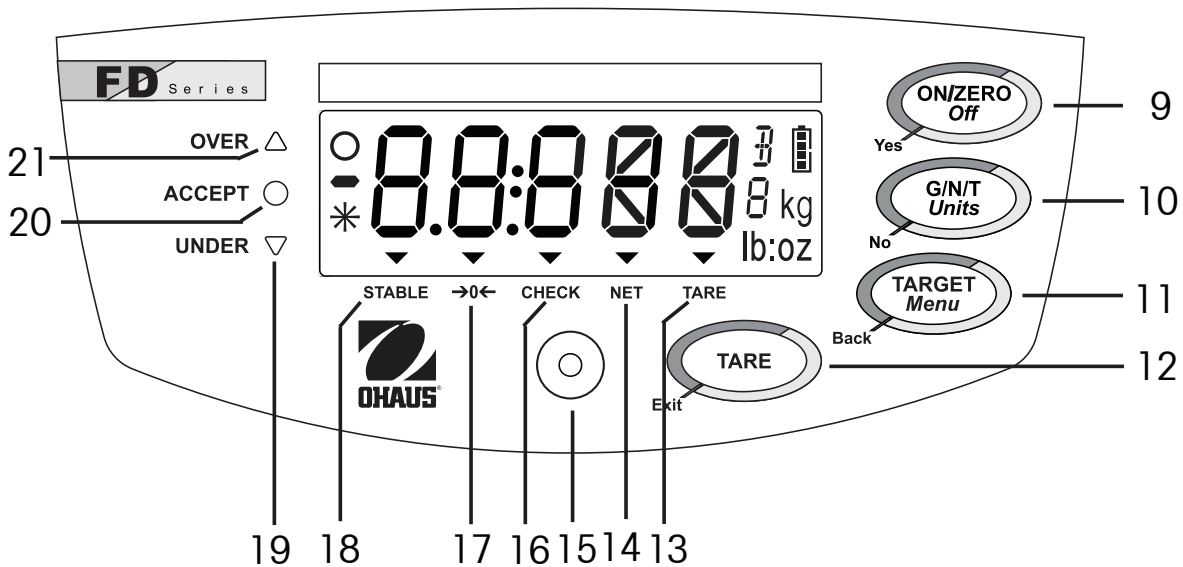

Figure 3-2. Control Panel.

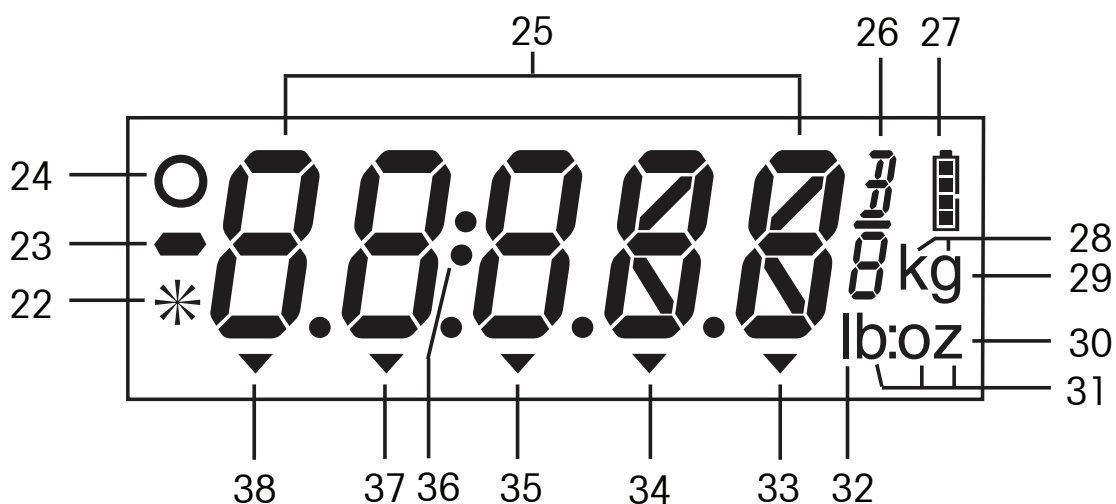

Figure 3-3. Display.





TABLE 3-1. PARTS AND CONTROLS.

Item	Description
1	Control buttons
2	Display
3	Data Label
4	Weighing pan
5	Adjustable leveling feet
6	Connection for AC adapter
7	Connection for optional foot switch
8	Security Cover
9	Power and Zero button
10	Gross/Net/Tare and Unit button
11	Target/Menu button
12	Tare button
13	Tare indicator
14	Net indicator
15	Leveling indicator
16	Checkweigh mode indicator
17	Center of Zero indicator
18	Stable indicator
19	Yellow Under LED

Item	Description
20	Green Accept LED
21	Red Over LED
22	Not used
23	Minus sign
24	Not used
25	7-segment display
26	Fractional ounce symbol
27	Battery charge symbol
28	Kilogram unit symbol
29	Gram unit symbol
30	Ounce unit symbol
31	Pound:Ounce unit symbol
32	Pound unit symbol
33	Tare indicator
34	Net indicator
35	Checkweigh mode indicator
36	Pound:Ounce separator
37	Center of Zero indicator
38	Stable indicator

## 3.2 Control Functions

Four multi-function buttons are used to operate the scale.

Button				
Primary Function (short press)	<b>ON / ZERO</b> <ul style="list-style-type: none"> <li>If scale is off, turns scale on</li> <li>If scale is on, sets zero</li> </ul>	<b>G/N/T</b> Momentarily Displays Gross Net and Tare values	<b>TARGET</b> Initiates target setting mode	<b>TARE</b> <ul style="list-style-type: none"> <li>Sets tare</li> <li>Clears tare, if pan is empty</li> </ul>
Secondary Function (long press)	<b>Off</b> If scale is on, turns scale off	<b>Units</b> Changes weighing unit	<b>Menu</b> Enters menu mode	None
Menu Function	<b>Yes</b> Accepts current setting and advances to the next menu item	<b>No</b> Rejects current setting or menu item and advances to the next available item	<b>Back</b> Reverts back to previous menu item	<b>Exit</b> <ul style="list-style-type: none"> <li>Immediately exits menu mode</li> <li>Aborts calibration in progress</li> </ul>
Target Setting Function	Shifts to next digit	Increments value of the active digit	Accepts current displayed value	Changes sign (+ / -) of displayed value

## 3.3 Basic Operation

### 3.3.1 Turning On

With the scale off, press the **ON/ZERO Off** button. The scale performs a display test, then displays zero.

### 3.3.2 Turning Off

With the scale on, press and hold the **ON/ZERO Off** button until OFF is displayed.

### 3.3.3 Zeroing

Remove the load from the pan and press the **ON/ZERO Off** button to set the display to zero. The Center of Zero indicator turns on when the measurement is within  $\pm 1/4$  d of the zero setting.

### 3.3.4 Taring

#### Semi-automatic Tare (Tare Button)

To store or change the Tare value, place an empty container on the pan and press the **TARE** button. The Net weight and NET indicator will be displayed.

To clear the Tare value, remove the container from the pan and press the **TARE** button. The NET indicator turns off and the gross weight will be displayed.

Automatic Tare (Refer to Section 3.7.3)

Auto-tare is a convenience feature that automatically tares the initial weight (such as an empty container) placed on the empty pan, without having to press the **TARE** button. The tare value is cleared automatically when the weight on the pan is fully removed.

Remote Tare (Foot Switch)

Taring with the optional foot switch is equivalent to pressing the **Tare** button.

3.3.5 Displaying Gross, Net and Tare Values

When a tare has been entered, pressing the **G/N/T** button successively displays the Tare (TARE indicator turns on), the Gross, and the Net weights (NET indicator turns on). After a few seconds the scale automatically reverts to displaying the NET weight.

3.3.6 Changing Unit of Measure

Press and hold the **Units** button until the desired unit is displayed. If one of the available units is not displayed, enable it as described in Section 3.7.4.

**3.4 Menu**

3.4.1 Menu Structure

The FD Series menu structure consists of three levels: Main, Sub-menu, and Menu item. The Main menu contains the Sub-menus and each Sub-menu contains several Menu items. Each Menu item contains two or more settings.

**TABLE 3-2. MENU STRUCTURE.**

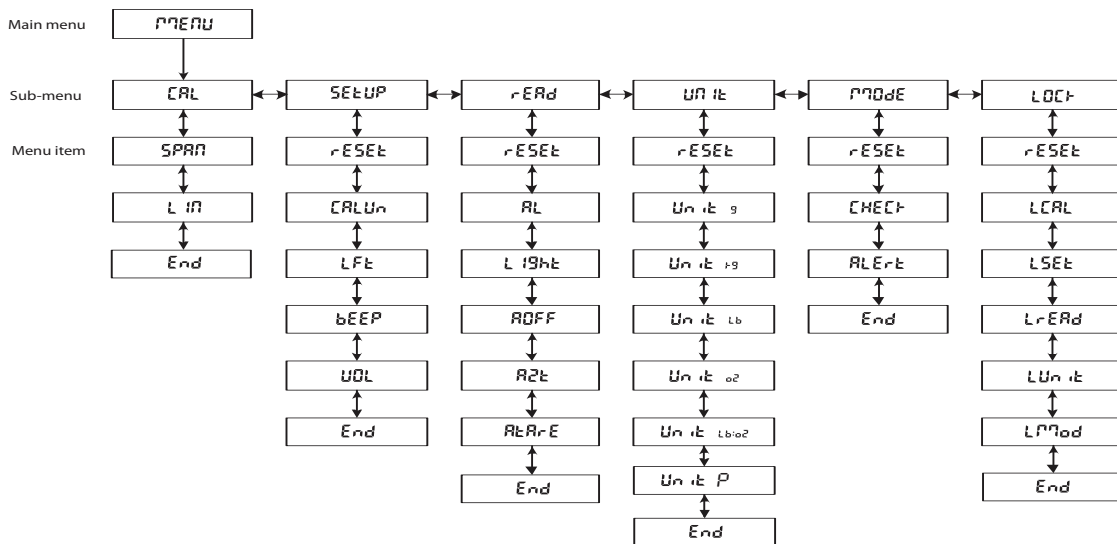

NOTE: LFT menu item and LOCK sub menu will not appear in FDxxH models

### 3.4.2 Menu Navigation

Use the four buttons marked with **Yes**, **No**, **Back** and **Exit** to navigate through the menus (refer to Section 3.2).

- **Yes** - Enters the displayed sub-menu or menu item and accepts the displayed setting.
- **No** - Skips to the next sub-menu or menu item and changes the displayed setting.
- **Back** - Goes back to the previous sub-menu or menu item.
- **Exit** - Immediately exits the Menu mode.

### 3.4.3 Changing Menu Settings

Enter the menu by holding down the **Menu** button until Menu is displayed. When the button is released, the first available sub-menu is displayed.

- Navigate to the desired sub-menu using the **No** button.
- Enter the sub-menu using the **Yes** button.
- Navigate to the desired menu item using the **No** button.
- Enter the desired menu item using the **Yes** button.
- Change the setting using the **No** button or accept the setting using the **Yes** button.
- Continue navigation using the **Yes**, **No** and **Back** buttons or return to weighing using the **Exit** button.

## 3.5 Application Modes

Two application modes are available in the FD Series: Weigh and Checkweigh. To enable the Checkweigh mode, Checkweigh must be turned on in the Mode menu (refer to Section 3.7.5).

### 3.5.1 Weighing

Determines the weight of an item in the selected unit of measure. The FD Series is shipped with kilograms (kg) and pounds (lb) enabled. To enable other units of measure, they must be turned on in the Unit menu (refer to Section 3.7.4).

### 3.5.2 Checkweighing

Use this mode to compare the weight of an item to Under and Over target limits. When the checkweigh mode is enabled, the "CHECK" indicator will turn on.

To set the target limits, refer to Section 3.6 Checkweigh Target Settings.

Place the sample on the weighing pan. If the sample weight is under the target weight range, the yellow LED will light. If the sample is within the target weight range, the green LED will light. If the sample is over the target weight range, the red LED will light. The LED indication is complemented by an audible alert feature (refer to Section 3.7.5).

#### Normal Checkweighing

Set both targets as positive values, where the lightest acceptable weight is entered as the Under target limit and the heaviest acceptable weight is entered as the Over target limit. Items placed on the pan will be compared to the targets.



### Negative Checkweighing

In "Negative" checkweighing, the part of an item subsequently removed from the pan is checked against the target limits. This method may be preferred in portioning applications.

- Set both targets as negative values, where the lightest acceptable weight is entered as the Under target limit and the heaviest acceptable weight is entered as the Over target limit.
- Place a quantity of items on the pan.
- Tare the items.
- Remove a portion of the items from the pan.
- The amount removed will be compared to the targets.

### "Zero" Checkweighing

In "Zero" checkweighing, displayed results will show the deviation of the sample's weight from a reference or ideal weight. This approach may be more preferred for grading or sorting applications.

- Set the targets using a negative value (negative tolerance) for the Under limit and a positive value (positive tolerance) for the Over limit.
- Place the reference weight on the pan.
- Tare the reference weight and remove it from the pan.
- Place the item on the pan to be checked against the reference weight.
- The display will show a negative, positive or "0" value if the sample is less than, more than or equal to the reference weight, respectively.

## 3.6 Checkweigh Target Settings

To set the target limits, begin by pressing the **TARGET** button. The value of the Under target limit will be displayed first, with the left-most digit blinking.

**Note:** The scale must be in checkweigh mode to be able to enter or modify target values.

- To change the Under target limit, press the **No** button to increment the flashing digit, the **Yes** button to shift to the next digit and the **Exit** button to change the sign.
- Press the **TARE** button to toggle the display between a positive and negative value.
- To accept the Under target limit, press the **TARGET** button.
- Next, the value of the Over target limit will be displayed, with the left-most digit blinking.
- Repeat the procedure above to set the Over target limit.
- When the Over target limit has been set, press the **TARGET** button to store the settings and begin Checkweighing.

## 3.7 Scale Settings

Enter the Menu mode. Proceed to a menu item and use the **Yes** and **No** buttons to view and select available scale settings. When the desired changes have been made, press **Exit** to return to weighing. Refer to Section 3.4 for more information on how to enter and navigate the menus.

### 3.7.1 Calibration sub-menu

**Note:** Calibration is not available when the scale has been set to Legal for Trade operation (LFT set to ON in the Setup sub-menu, refer to Section 3.7.2).

Calibration Types – The FD Series' calibration can be adjusted in two ways, Span and Linearity. Span calibration uses two calibration points to adjust the sensitivity of the scale. Linearity calibration uses three calibration points to correct for non-linear weighing results.

Calibration Weights – Before beginning calibration, make sure that the required calibration weights are available. The model-specific calibration points are listed in the table below.

**TABLE 3-3. CALIBRATION POINTS.**

<b>Model</b>	<b>Calibration Unit</b>	<b>Span Calibration Points</b>	<b>Linearity Calibration Points</b>
FD3/ FD3H	kg lb	1, 2 or <b>3 kg</b> 2, 5 or <b>6 lb</b>	<b>1</b> or 2 and <b>3 kg</b> <b>2</b> or 4 and <b>6 lb</b>
FD6/ FD6H	kg lb	2, 5 or <b>6 kg</b> 5, 10 or <b>15 lb</b>	<b>2</b> or 4 and <b>6 kg</b> <b>5</b> or 10 and <b>15 lb</b>
FD15/ FD15H	kg lb	5, 10 or <b>15 kg</b> 10, 20 or <b>30 lb</b>	<b>5</b> or 10 and <b>15 kg</b> <b>10</b> or 20 and <b>30 lb</b>

**Notes:**

1. Default calibration points are shown in bold print.
2. Calibration Units kg or lb are selected in the Setup sub-menu (Section 3.7.2.)
3. ASTM Class 4 or OIML Class F2 weights are required for calibration.

Span Calibration Procedure

- When CAL is displayed, press **Yes** to enter the calibration sub-menu.
- When Span is displayed, press **Yes** to begin the Span calibration process.
- Clear the pan if prompted to do so, then press **Yes**.
- The display will show "--C--", followed by the span calibration weight value.
- If desired, press **No** to change to an alternate span calibration weight value.
- Place the indicated calibration weight on the scale and press **Yes**.
- The display will show "--C--", then "done" and then revert to weighing. Remove the calibration weight.

**Note:** The calibration procedure can be canceled at any time by pressing the **Exit** button or turning the scale off.

Linearity Calibration Procedure

- When LIN is displayed, press **Yes** to begin the linearity calibration process.
- Clear the pan if prompted to do so, then press **Yes**.
- The display will show "--C--", followed by the first calibration weight value.
- If desired, press **No** to change to an alternate first calibration weight value.
- Place the indicated calibration weight on the scale and press **Yes**.
- The display will show "--C--", followed by the second calibration weight value.
- Place the indicated calibration weight on the scale and press **Yes**.
- The display will show "--C--", then "done" and then revert to weighing. Remove the calibration weight.

**Note:** The calibration procedure can be canceled at any time by pressing the **Exit** button or turning the scale off.

End

- Press **Yes** to leave this sub-menu and go to the next.
- Press **No** to return to the top menu item in this sub-menu.

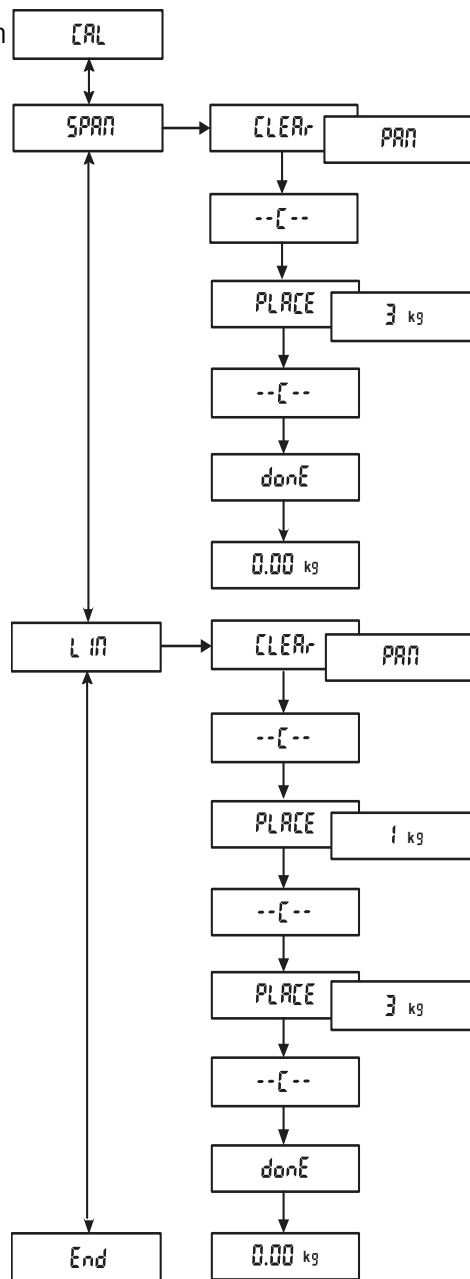

### 3.7.2 Setup sub-menu

Press **Yes** to enter the Setup sub-menu.

#### Reset

Press **Yes** to enter the Reset menu.

- **No** - does not change the Setup sub-menu settings.
- Yes - reset the Setup sub-menu to the factory default settings (bold and underlined text herein).

#### Calibration Unit

Press **Yes** to enter the Calibration Unit menu.

- **kg** - calibrate using kilogram weights.
- lb - calibrate using pound weights.

#### Legal for Trade

Press **Yes** to enter the LFT menu.

- **Off** - set the scale for non-Legal for Trade operation.
- On - set the scale for Legal for Trade operation.

**Note:** See section 3.8 for information related to Legal for Trade operation.

#### Beeper

Press **Yes** to enter the Beeper menu.

- **Off** - beeper does not sound when a button is pressed.
- On - beeper sounds when a button is pressed.

#### Volume

Press **Yes** to enter the Beeper Volume menu.

- **Soft** - volume of beeper is low.
- Loud - volume of beeper is high.

#### End

- Press **Yes** to leave this sub-menu and go to the next.
- Press **No** to return to the top menu item in this sub-menu.

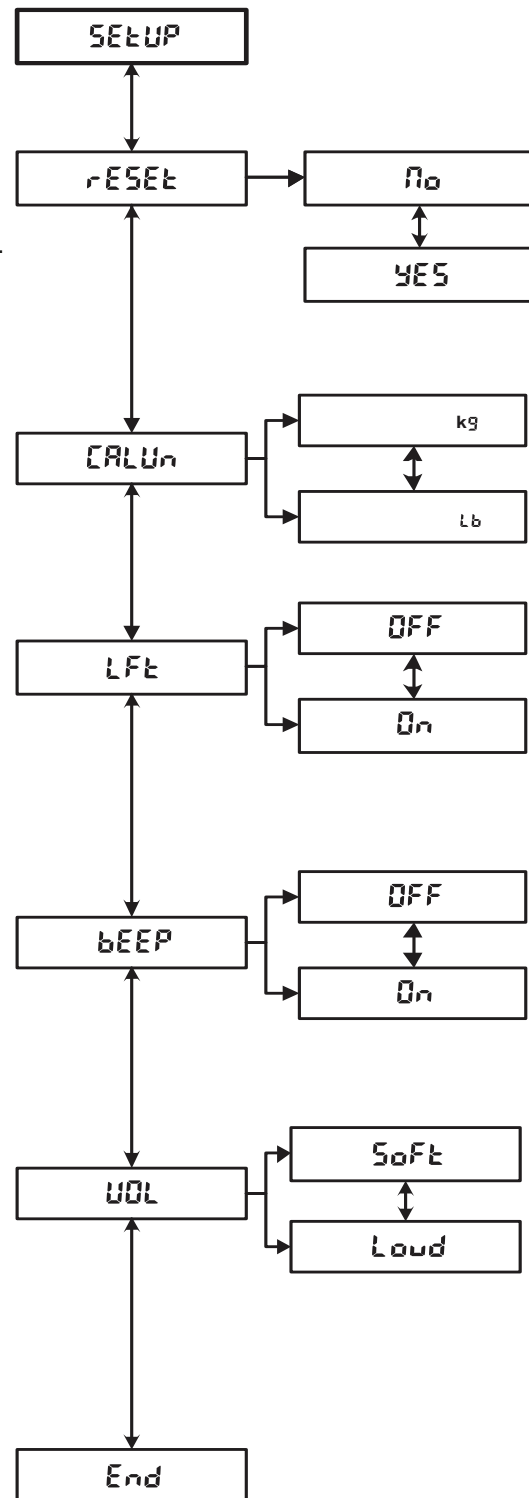

### 3.7.3 Readout sub-menu

Press **Yes** to enter the Readout sub-menu.

#### Reset

Press **Yes** to enter the Reset menu.

- **No** - does not change the Readout sub-menu settings.
- **Yes** - reset the Readout sub-menu to the factory default settings (bold and underlined text herein).

#### Averaging Level

Press **Yes** to enter the Averaging Level menu.

- **Lo** - less filtering (faster stabilization time).
- **Hi** - more filtering (longer stabilization time).

#### Light

Press **Yes** to enter the Backlight menu.

- **Off** - turn display backlight off.
- **On** - turn display backlight on.
- **Auto** - automatically turns the display backlight on when the scale is active and off after 5 seconds of inactivity.

#### Auto Off

Press **Yes** to enter the Auto-off menu.

- **Off** - disable auto off.
- **On** - turn the scale off after 5 minutes of inactivity.

#### Auto Zero tracking

Press **Yes** to enter the Auto Zero Tracking menu.

- **0.5 d** - 1/2 division capture range.
- **1 d** - 1 division capture range.
- **3 d** - 3 division capture range.
- **Off** - disable Auto Zero Tracking.

#### Auto Tare

Press **Yes** to enter the Automatic Tare menu.

- **Off** - disable Automatic Tare.
- **On** - enable Automatic Tare.

#### End

- Press **Yes** to leave this sub-menu and go to the next.
- Press **No** to return to the top menu item in this sub-menu.

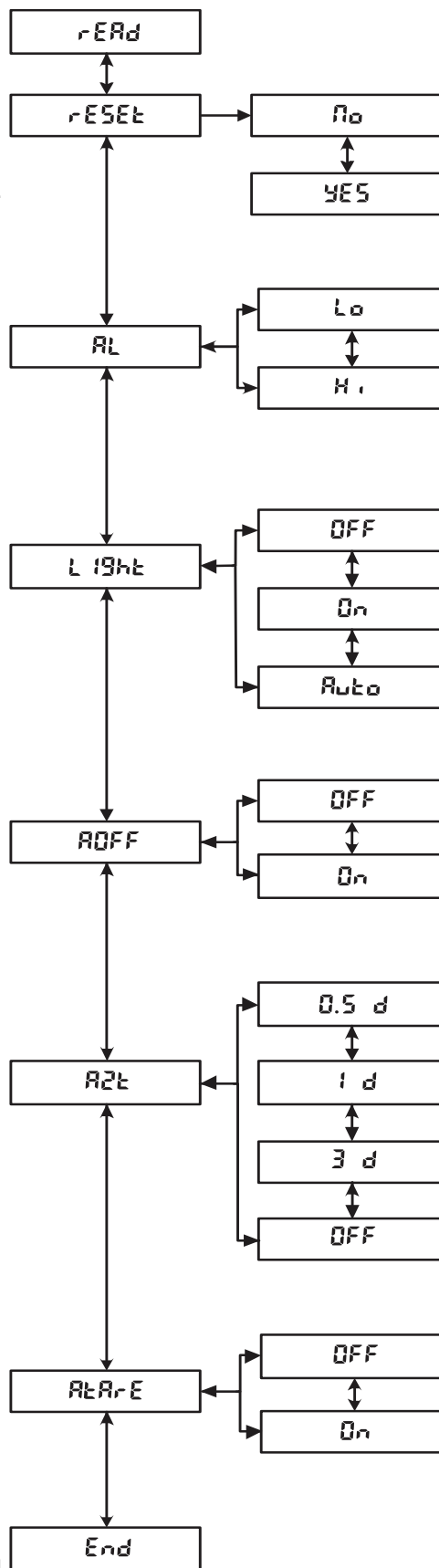

### 3.7.4 Unit sub-menu

Press **Yes** to enter the Unit sub-menu.

Reset

Press **Yes** to enter the Reset menu.

- **No** - does not change the Unit sub-menu settings.
- **Yes** - reset the Unit sub-menu to the factory default settings (bold and underlined text herein).

Gram unit

Press **Yes** to enter the Gram unit menu.

- **Off** - disable grams.
- **On** - enable grams.

Kilogram unit

Press **Yes** to enter the Kilogram unit menu.

- **Off** - disable kilograms.
- **On** - enable kilograms

Pound unit

Press **Yes** to enter the Pound unit menu.

- **Off** - disable pounds.
- **On** - enable pounds.

Ounce unit

Press **Yes** to enter the Ounce unit menu.

- **Off** - disable ounces.
- **dEC** - enable decimal ounces.
- **FrAC** - enable fractional ounces.

Pound:Ounce unit

Press **Yes** to enter the Pound Ounce unit menu.

- **Off** - disable pound ounces.
- **dEC** - enable decimal pound ounces.
- **FrAC** - enable fractional pound ounces.

P(Percent) unit\*

Press **Yes** to enter the P unit menu.

- **Off** - disable p.
- **On** - enable p.

End

- Press **Yes** to leave this sub-menu and go to the next.
- Press **No** to return to the top menu item in this sub-menu.

\*Use P to measure the weight of a sample as a % of ref. weight. When P is selected display will show S.ref and P.Press "No" to use ref. weight in memory,"Yes" to establish new ref.After placing reference material, press "Yes" to establish 100% ref.Replace ref. material with new sample to read percentage of the sample compared to ref. weight

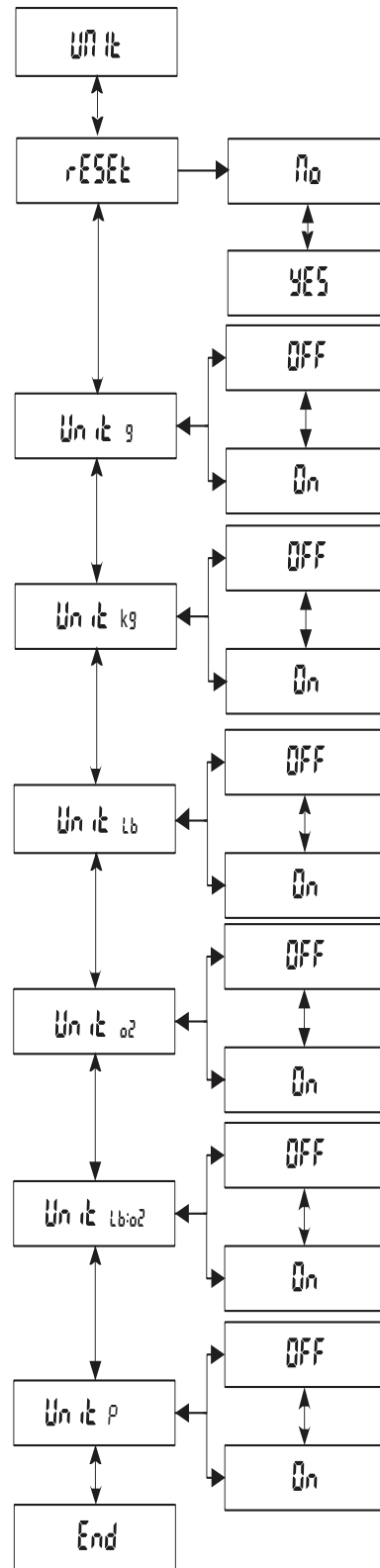

### 3.7.5 Mode sub-menu

Press **Yes** to enter the Mode sub-menu.

Reset

Press **Yes** to enter the Reset menu.

- **No** - does not change the Mode sub-menu settings.
- **Yes** - reset the Mode sub-menu to the factory default settings (bold and underlined text herein).

Checkweigh mode

Press **Yes** to enter the Checkweigh menu.

- **Off** - disable the Checkweighing mode.
- **On** - enable the Checkweighing mode.

Alert

Press **Yes** to enter the Checkweigh Alert menu.

- **Off** - disable alert beeping.
- **OK** - beep when the green Accept light is on.
- **Lo** - beep when the yellow Under light is on.
- **Hi** - beep when the red Over light is on.
- **Lo-Hi** - beep when the yellow Under or red Over light is on.
- **Change** - beep once when the green Accept light is on, twice when the red Over light is on.

End

- Press **Yes** to leave this sub-menu and go to the next.
- Press **No** to return to the top menu item in this sub-menu.

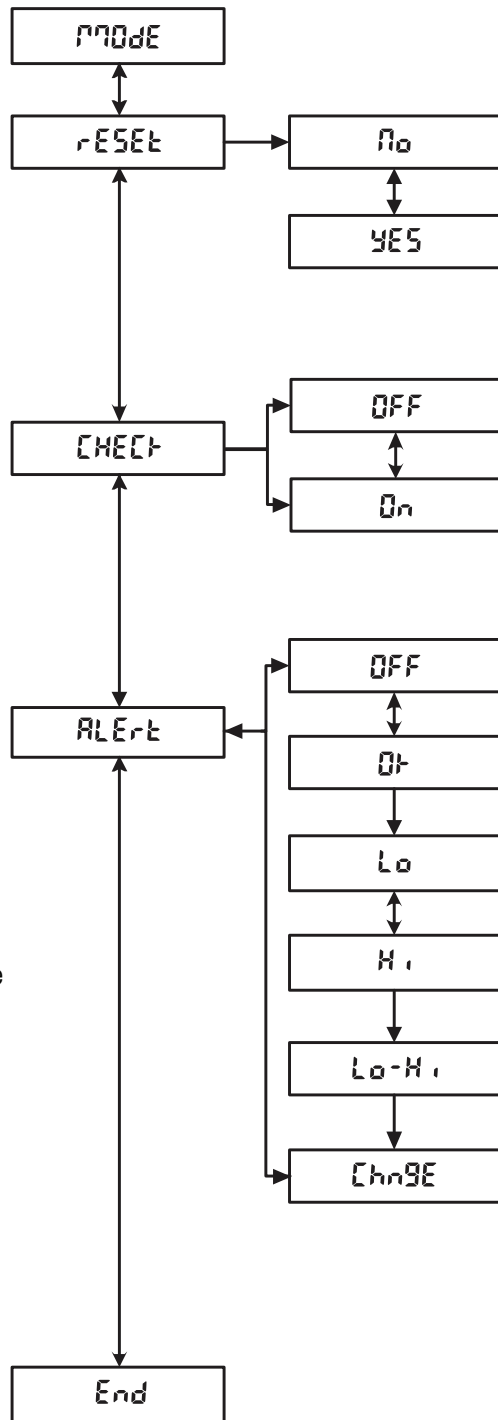

### 3.7.6 Lockout sub-menu

Press **Yes** to enter the Lockout sub-menu.

Reset

Press **Yes** to enter the Reset sub-menu.

- **No** - does not change the Lockout sub-menu settings.
- **Yes** - reset the Lockout sub-menu to the factory default settings (bold and underlined text herein).

Lock Calibration

Press **Yes** to enter the Lock Calibration sub-menu.

- **Off** - enable changes to the Calibration sub-menu.
- **On** - lock Calibration sub-menu settings.

Lock Setup

Press **Yes** to enter the Lock Setup sub-menu.

- **Off** - enable changes to the Setup sub-menu.
- **On** - lock Setup sub-menu settings.

Lock Readout

Press **Yes** to enter the Lock Readout sub-menu.

- **Off** - enable changes to the Readout sub-menu.
- **On** - lock Readout sub-menu settings.

Lock Unit

Press **Yes** to enter the Lock Unit sub-menu.

- **Off** - enable changes to the Unit sub-menu.
- **On** - lock Unit sub-menu settings.

Lock Mode

Press **Yes** to enter the Lock Mode sub-menu.

- **Off** - enable changes to the Mode sub-menu.
- **On** - lock Mode sub-menu settings.

End

- Press **Yes** to leave this sub-menu and go to the next.
- Press **No** to return to the top menu item in this sub-menu.

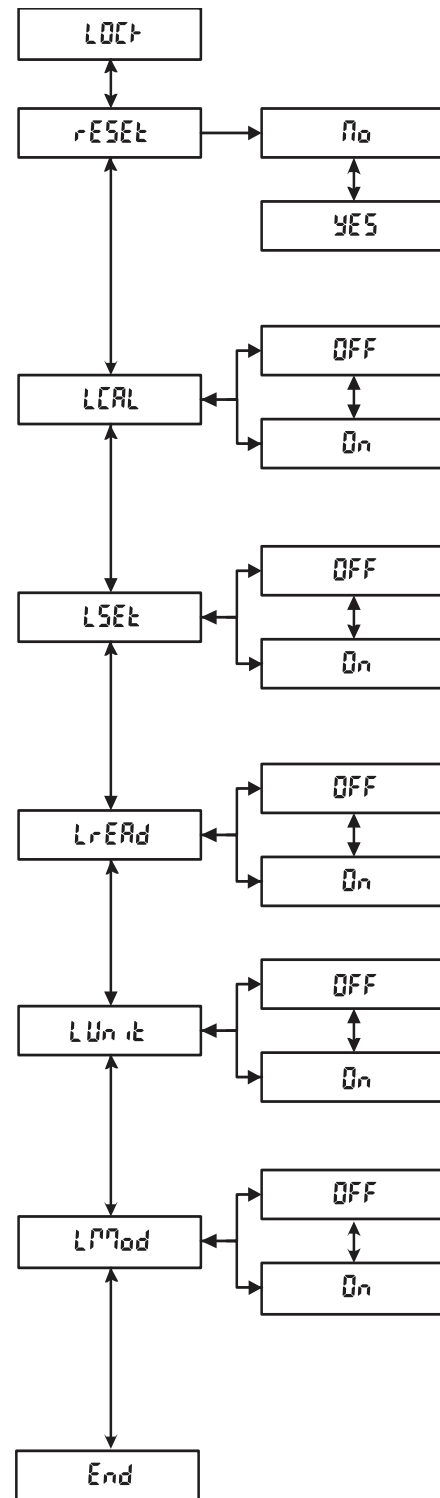



### 3.8 Legal for Trade Settings

The FD Series is designed to comply with OIML, EEC, NTEP and Measurement Canada weights and measures regulations. These approvals may be pending; contact Ohaus for further details about availability.

**Note:**

Consult your local Weights and measures office for their regulations before placing the scale into a Legal for Trade application.

When the LFT menu item setting is On, the following conditions apply:

- The Calibration (CAL) sub-menu is hidden.
- The Calibration Lock (LCAL) menu item is hidden.
- The Auto Zero Tracking (AZt) menu item is set to 0.5 d.
- lb:oz unit is disabled.

When the weights and measures official has approved the scale for use, it should be sealed using one of the methods shown in Section 3.9.

### 3.9 Sealing the Scale

When used in conjunction with the Lockout menu and the security switch, the scale may be sealed to prevent or detect unauthorized changes to scale settings. For Legal for Trade applications, set the LFT menu item to ON, set the security switch to the On position, then seal the scale to prevent access to the metrological parameters. Seal the scale according to the local weights and measures regulations.

Sliding the switch to the ON position in FDxxH models will freeze the menu item settings in their current state

To regain access to the scale settings, break the seal and set the security switch to the OFF position.

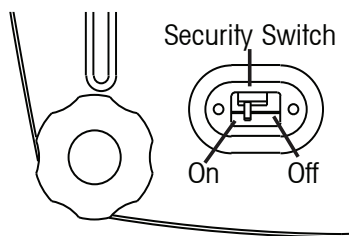
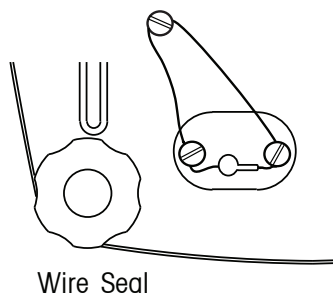

Figure 3-4. Security Switch Settings.

Wire Seal

Remove the spacers under the cross drilled screws. Feed the wire through the cross drilled holes.



Wire Seal

Paper Seal

Place the paper seals over the screws and sealing spacers.

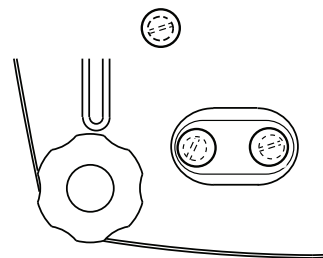

Paper Seal

Figure 3-5. Sealing methods.

## 4 MAINTENANCE

### 4.1 Calibration

Verify calibration periodically by placing either a ASTM Class 4 weight or an OIML Class F2 weight on the scale and compare the reading to the specifications. Refer to Section 3.7.1 for calibration procedure.

### 4.2 Cleaning

- Disconnect the scale from the power supply before cleaning.
- The housing and pan should be kept clean and free from foreign material.
- Wipe the exterior components of the scale using a soft cloth dampened with water and a mild detergent (do not use acids, alkalis or strong solvents).
- The leveling feet and load pads may be unscrewed and removed for cleaning.
- Do not allow liquids to enter the scale.
- Remove and clean the pan separately from the scale.
- The pan is dishwasher safe and may be placed with normal loads. All other parts must not be placed in a dishwasher.

### 4.3 Troubleshooting

The following table lists common problems, possible causes and remedies. If the problem persists, contact Ohaus or your authorized Ohaus dealer.

**TABLE 4-1. TROUBLESHOOTING.**

Symptom	Possible Causes	Remedy
Scale will not turn on.	AC power not connected.	Connect scale to power.
	Battery discharged.	Connect scale to power and charge battery.
Battery indicator is low.	Battery discharged.	Connect scale to power and charge battery.
Battery fails to charge fully.	Battery is defective.	Have the battery replaced by an authorized Ohaus service dealer.
Weight reading does not stabilize.	Unstable environment.	Ensure a stable environment.
	Interference under pan.	Ensure that the weighing pan is unobstructed and free to move.
		Change the Averaging Level setting.
Scale does not display accurately.	Improper calibration.	Calibrate scale.
Cannot calibrate the scale.	Calibration locked.	Set LFT to OFF in the Menu Mode.
		Set LCAL to OFF in the Menu Mode.
		Set Security switch to the Off position.

**TABLE 4-2. ERROR CODES.**

<b>Error Code</b>	<b>Cause</b>	<b>Remedy</b>
Err 1 (Overload)	Load exceeds capacity.	Reduce load.
Err 2 (Underload)	Missing pan.	Install the pan and press the zero button.
Err 9 (Checksum error)	Configuration data checksum error.	Service required.
Err14 (Zero error)	Zero limit exceeded during power up.	Remove load from pan.
Err 21 (Checksum error)	Calibration data checksum error.	Check menu settings and recalibrate. If error persists, service is required.
CAL E (Calibration error)	Wrong calibration weight values used.	Calibrate using correct calibration weights.

## 4.4 Service Information

If the Troubleshooting section does not resolve or describe your problem, contact your authorized Ohaus Service Agent. For Service assistance in the United States and Canada, please call Ohaus Corporation toll free at (800) 526-0659 from 8 AM to 5 PM Eastern Time. An Ohaus Product Service Specialist will be available to help you.

## 4.5 Accessories

### Description

Foot Switch

### Part Number

71169633

## 5 TECHNICAL DATA

### 5.1 Drawings

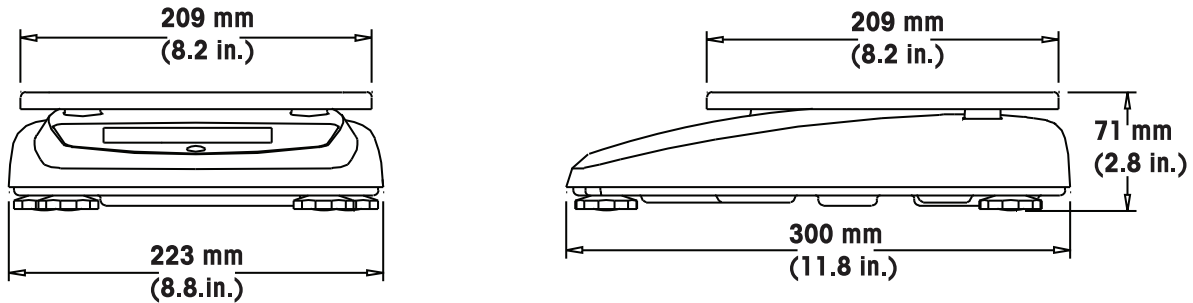

Figure 5-1. Scale Dimensions.

### 5.2 Specifications

The specifications apply under the following ambient conditions:

Temperature range:	-10 to 40 °C
Atmospheric humidity:	Maximum relative humidity 80% for temperatures up to 31 °C decreasing linearly to 50% relative humidity at 40 °C.
Overvoltage category:	II
Pollution degree:	2
Maximum altitude:	4000 m above sea level

TABLE 5-1. SPECIFICATIONS.

Model	FD3	FD6	FD15
Capacity x Readability (Max x d non-approved)	3 kg x 0.0005 kg 3000 g x 0.5 g 6 lb x 0.001 lb 96 oz x 0.02 oz 96 oz x 1/4 oz 6 lb 0 oz x 0.1 oz 6 lb 0 oz x 1/4 oz	6 kg x 0.001 kg 6000 g x 1 g 15 lb x 0.002 lb 240 oz x 0.05 oz 240 oz x 1/4 oz 15 lb 0 oz x 0.1 oz 15 lb 0 oz x 1/4oz	15 kg x 0.002 kg 15000 g x 2 g 30 lb x 0.005 lb 480 oz x 0.1 oz 480 oz x 1/4 oz 30 lb 0 oz x 0.1 oz 30 lb 0 oz x 1/4 oz
Maximum displayed resolution	1:6000	1:7500	1:7500
Capacity x Readability (Max x e approved)	3 kg x 0.001 kg 3000 g x 1 g 6 lb x 0.002 lb 96 oz x 0.05 oz 96 oz x 1/4 oz	6 kg x 0.002 kg 6000 g x 2 g 15 lb x 0.005 lb 240 oz x 0.1 oz 240 oz x 1/4 oz	15 kg x 0.005 kg 15000 g x 5 g 30 lb x 0.01 lb 480 oz x 0.2 oz 480 oz x 1/4 oz
Approved resolution	1:3000	1:3000	1:3000
Repeatability	0.001 kg	0.002 kg	0.005 kg
Linearity	±0.001 kg	±0.002 kg	±0.005 kg
Weighing units	g, kg, lb, oz (decimal/fractional), lb:oz (decimal/fractional oz)		
Weight display	5-digit 19 mm high digits, 7-segment back lit LCD display (with fractional ounce and battery status indicator)		
Keyboard	4 - button membrane switch		
Application modes	Weighing, Checkweighing, Percentage		
Checkweigh indication	3 LEDs (yellow, green, red) with configurable alert beeper		
Power	9-12 VDC 0.5-0.8A AC Adapter Internal rechargeable sealed lead-acid battery		
Typical battery life	120 hours with 15 hour recharge time		
Tare range	To capacity by subtraction		
Stabilization time	Within 2 seconds		
Auto zero tracking	Off, 0.5, 1 or 3 divisions		
Operating temperature range	-10 °C to 40 °C / 14 °F to 104 °F		
Storage temperature range	-40 °C to 70 °C / -40 °F to 158 °F		
Approved temperature range	0 °C to 40 °C / 32 °F to 104 °F		
Protection	IP43		
Construction	304 Stainless steel housing and platform		
Pan size (DxW)	209 x 209mm / 8.2 x 8.2 in.		
Scale dimensions (DxWxH)	300 x 223 x 71 mm / 9 x 12 x 2.8 in.		
Shipping dimensions (DxWxH)	400 x 320 x 185mm / 15.8 x 12.6 x 7.3in.		
Scale weight	3.6kg / 8.0lb		
Shipping weight	5kg / 11lb		

**Note:** Product specifications are subject to change without any obligation on the manufacturer.

TABLE 5-2. SPECIFICATIONS.

Model	FD3H	FD6H	FD15H
Capacity x Readability (Max x d non-approved)	3 kg x 0.0001 kg 3000 g x 0.1 g 6 lb x 0.0002 lb 96 oz x 0.005 oz 96 oz x 1/4 oz 6 lb 0 oz x 0.1 oz 6 lb 0 oz x 1/4 oz	6 kg x 0.0002 kg 6000 g x 0.2 g 15 lb x 0.001 lb 240 oz x 0.01 oz 240 oz x 1/4 oz 15 lb 0 oz x 0.1 oz 15 lb 0 oz x 1/4oz	15 kg x 0.001 kg 15000 g x 1 g 30 lb x 0.001 lb 480 oz x 0.02 oz 480 oz x 1/4 oz 30 lb 0 oz x 0.1 oz 30 lb 0 oz x 1/4 oz
Maximum displayed resolution	1:30000	1:30000	1:30000
Repeatability	0.0002 kg	0.0004 kg	0.002 kg
Linearity	±0.0002 kg	±0.0004 kg	±0.002 kg
Weighing units	g, kg, lb, oz (decimal/fractional), lb:oz (decimal/fractional oz)		
Weight display	5-digit 19 mm high digits, 7-segment back lit LCD display (with fractional ounce and battery status indicator)		
Keyboard	4 - button membrane switch		
Application modes	Weighing, Checkweighing, Percentage		
Checkweigh indication	3 LEDs (yellow, green, red) with configurable alert beeper		
Power	9-12 VDC 0.5-0.8 A AC Adapter Internal rechargeable sealed lead-acid battery		
Typical battery life	120 hours with 15 hour recharge time		
Tare range	To capacity by subtraction		
Stabilization time	Within 2 seconds		
Auto zero tracking	Off, 0.5, 1 or 3 divisions		
Operating temperature range	-10 °C to 40 °C / 14 °F to 104 °F		
Storage temperature range	-40 °C to 70 °C / -40 °F to 158 °F		
Approved temperature range	0 °C to 40 °C / 32 °F to 104 °F		
Protection	IP43		
Construction	304 Stainless steel housing and platform		
Pan size (DxW)	209 x 209mm / 8.2 x 8.2 in.		
Scale dimensions (DxWxH)	300 x 223 x 71 mm / 9 x 12 x 2.8 in.		
Shipping dimensions (DxWxH)	400 x 320 x 185mm / 15.8 x 12.6 x 7.3in.		
Scale weight	3.6kg / 8.0lb		
Shipping weight	5kg / 11lb		

**Note:** Product specifications are subject to change without any obligation on the manufacturer.

## LIMITED WARRANTY

Ohaus products are warranted against defects in materials and workmanship from the date of delivery through the duration of the warranty period. During the warranty period Ohaus will repair, or, at its option, replace any component(s) that proves to be defective at no charge, provided that the product is returned, freight prepaid, to Ohaus.

This warranty does not apply if the product has been damaged by accident or misuse, exposed to radioactive or corrosive materials, has foreign material penetrating the inside of the product, or as a result of service or modification by other than Ohaus. In lieu of a properly returned warranty registration card, the warranty period shall begin on the date of shipment to the authorized dealer. No other express or implied warranty is given by Ohaus Corporation. Ohaus Corporation shall not be liable for any consequential damages.

As warranty legislation differs from state to state and country to country, please contact your local Ohaus dealer for further details.